

A 3D rendering of a BMR-100 rotary level control device. It features a white cylindrical top section with a red interior, a central shaft, and a blue propeller-like base.

**BMR-100**  
**ROTARY LEVEL CONTROL**

**OPERATING INSTRUCTIONS**  
**PLEASE READ CAREFULLY**

# Contents

**General Specifications**

---

**Safety Summary**

---

**1.0 Introduction**

---

**2.0 Installation**

---

**2.2 Location and Mounting**

---

**2.3 Input Power and Field Wiring**

---

**2.4 Grounding**

---

**3.0 Spdt Indicator Switch**

---

**4.0 Warranty and Customer Service**

---

**5.0 Disposal**

---



# BMR-100 Rotary Level Control



## SPECIFICATIONS

### BMR-100 GENERAL SPECIFICATIONS

**Supply:** 115 VAC 50/60 Hz

**Supply Tolerance:** -15% to +10%

**Load:** AC Model 4 VA

**Ambient Temperature:** (Electronics) -40° F to +185° F (-40° C to +85° C)

**Enclosure:** Type 4X, 5, & 12 / IP66

**Relay Output:** SPDT contacts; 10 Amps 250 VAC

**Mounting:** 1 1/4" NPT

**Conduit Entry:** 3/4" NPT

**Shaft Seal:** 1/2 micron, 30 PSI

**Enclosure:** Die cast Aluminum, USDA approved powder coat finish

## SAFETY

### SAFETY SUMMARY

Review the following safety precautions to avoid injury and prevent damage to the equipment.

The product should be installed, commissioned, and maintained by qualified and authorized personnel only.

Install according to installation instructions and comply with all National and Local codes.

Use electrical wire that is sized and rated for the maximum voltage and current of the application.

Properly ground the enclosure to an adequate earth ground.

Observe all terminal and relay contact ratings as called out on the nameplate and in the installation manual.

Ensure that the enclosure cover is in place and secured tightly during normal operation.

In potentially wet environments, thoroughly seal all conduit entries.

If this product is used in a manner not specified by the manufacturer the safety protection could be compromised.

### SAFETY TERMS AND SYMBOLS

**⚠ WARNING:** Warning statements identify conditions or practices that could result in injury or loss of life.  
Risk of electrical shock.

**⚠ CAUTION:** Caution statements identify conditions or practices that could result in damage to this product or other property.

## INTRODUCTION

### 1.0 INTRODUCTION

The BinMaster BMR-100 is a rotating paddle style level sensor which provides reliable point level detection for bulk solids, including powder, pellet, and granular materials. The BMR-100 motor rotates the drive shaft and paddle at 1 RPM. When the vessel material fills to the level of the indicator paddle, the material causes the paddle to stop rotating indicating a covered condition. When the material falls away, the paddle starts rotating again to indicate an uncovered condition.

## 2.0 INSTALLATION

### 2.1 Locating and Mounting

#### TOP MOUNT

1. Locate and cut hole in top of bin to fit outside diameter of 1 1/4" pipe coupling (1.950").
2. Position coupling halfway into bin and weld.
3. Turn unit so conduit opening is in desired location.
4. Add 1/4" extension pipe to desired length with standard 1/4" coupling on bottom end.
5. Cut 1 1/4" support pipe approximately 4" shorter than overall length of 1/4" pipe shaft when used with flexible coupling.
6. Insert 1 1/4" pipe into coupling and tighten.
7. Insert paddle into 1/4" coupling and drill holes for lock pins.

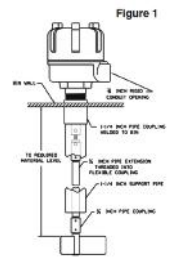

#### SIDE MOUNT

1. Locate and cut hole inside of bin to fit outside diameter of 1 1/4" pipe coupling.
2. Weld on half of standard 1 1/4" pipe coupling to bin wall flush with inside of bin.
3. Insert hub into coupling and turn to desired conduit position.
4. Screw paddle into place and replace lock pin.
5. Shaft and paddle should be shielded in low level mounting when subjected to material flow.
6. For side mount, a solid coupler is recommended.

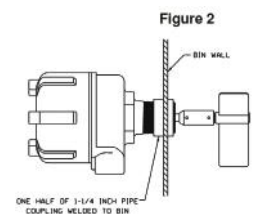

# BMR-100 Rotary Level Control



## Mounting Plates

Mounting plates are necessary when a completely assembled unit is to be mounted on the bin wall from the outside. A 5 1/2" hole is cut in the bin. Six bolt holes are drilled around the hole to match the mounting plate. The plate, with the unit attached, is then bolted in place. All mounting plates are available in carbon and stainless steel.

## Full Coupling

For use with all Rotary level controls. This model is used for top of bin installations where shaft extensions and shaft guards are required.

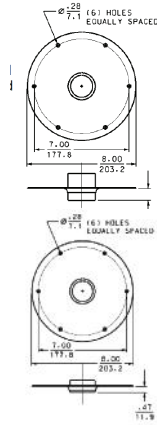

## Half Coupling

For use with all Rotary level controls. This model is used primarily for side of bin installations.

## ⚠ 2.2 Input Power and Field Wiring

The BMR-100 is available in 115 VAC 50/60 Hz supply voltage. See the voltage rating on the nameplate for the appropriate supply voltage. Field wiring should conform to all national and local electrical codes and any other agency or authority having jurisdiction over the installation. For power input, use wire that is sized and rated for the maximum voltage and current as per equipment ratings and has a temperature rating of at least 70 degrees C. For the SPDT switch output, use wire that is sized and rated for the maximum voltage and current as per application, up to 250 VAC 10A, and has a temperature rating of at least 70 degrees C. Installation shall be done by qualified personnel.

**NOTE: Make sure to open the screw terminals fully before inserting wiring.**

## BMR100 WIRING

### Input Power

Power input to the BMR-100 is connected to the POWER terminals labeled L and N.

### ⚠ AC Models

On AC models if one of the conductors is grounded, it should be connected to the N terminal. The ungrounded conductor should be connected to the L terminal. If neither conductor is grounded, then one of them is connect to the N terminal and the other to the L terminal.

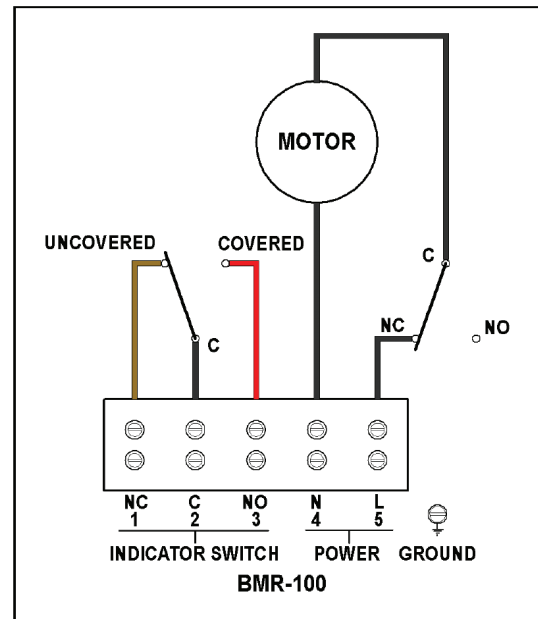

## ⚠ 2.3 Grounding

An equipment grounding connection (earth ground) must be supplied to the unit for safety. Connect the ground conductor to the green equipment grounding screw identified in the enclosure.

## 3.0 SPDT INDICATOR SWITCH

The SPDT Indicator switch is a set of switch contacts where the C terminal makes connection to the NC terminal when the paddle is uncovered. When the paddle becomes covered, the C terminal breaks the connection to the NC terminal and will make a connection to the NO terminal. What voltage is on the C terminal will be present on the NC terminal when the paddle is uncovered and when the paddle is covered the voltage on C terminal will be present on NO terminal.

## 4.0 WARRANTY AND CUSTOMER SERVICE

### 4.1 Limited Warranty

#### LIMITED PRODUCT WARRANTY.

Products manufactured by Seller are warranted for a period of one (1) year from date of shipment against defective materials and workmanship (the "Warranty Period"). SELLER MAKES NO OTHER WARRANTY, EXPRESS OR IMPLIED, AND ANY WARRANTY OF MERCHANTABILITY OR FITNESS FOR A PARTICULAR PURPOSE IS HEREBY DISCLAIMED AND EXCLUDED. This limited warranty does not extend to labor charges or other costs related to the removal and/or replacement of defective products or services. Any technical advice or services furnished by Seller with respect to the products is given without charge, and Seller assumes no obligation or liability for the advice given or results obtained, all such advice being given and accepted at Buyer's sole risk and expense. If the products are being acquired for resale, Buyer will make, in connection with any such resale, only those warranties contained herein and will indemnify Seller and its officers, directors, agents, employees, affiliates, successors, and assigns against any claims, causes of actions and judgments which arise from any representations, warranties, or agreements made by or entered into by Buyer, other than those contained herein.

#### WARRANTY EXCLUSIONS.

Notwithstanding Seller's Limited Product Warranty, products that have been or are (1) damaged by accident, corrosion, the elements, abuse, misuse, misapplication, vandalism, negligence, improper transportation, handling, storage, use or lack of proper and reasonable maintenance, (2) repaired or altered by anyone other than Seller or its authorized service providers, (3) modified or altered without Seller's written authorization, or (4) specially manufactured by Seller as per specifications provided by Buyer, are expressly excluded from Seller's Limited Product Warranty.

### 4.2 Customer Service

BinMaster offers a toll-free Customer Service phone number 1-800-278-4241. You may call the Customer Service Department for technical and application assistance Monday through Friday from 8:00 AM to 5:00 PM Central Time. International customers call us at (402) 434-9102 or reach us via fax at (402) 434-9133.

## 5.0 DISPOSAL

This product consists of materials that can be recycled by specialized recycling companies. It uses recyclable materials and the electronics are designed to be easily separated. Consult local authorities for proper disposal locations.

## MOUNTING INSTRUCTIONS

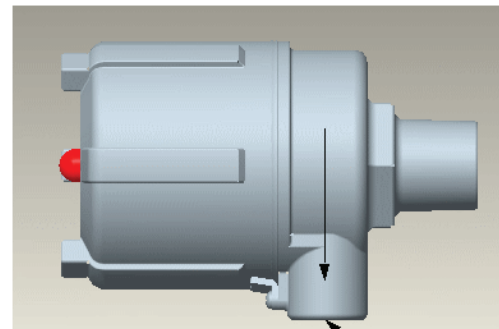

Always Mount Unit With  
Conduit opening down

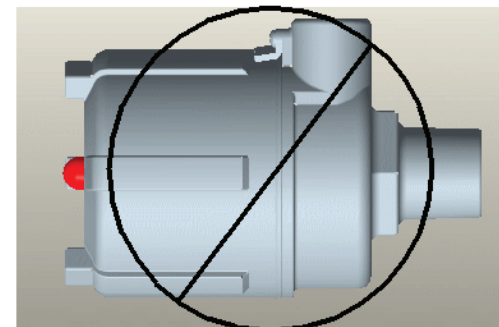

### Conduit Seal

When installing this level indicator in environments where it is possible for moisture or moist air to enter the enclosure through the electrical conduit, the conduit opening should be sealed with a duct seal compound or putty appropriate for the purpose.



## HMA GROUP

**MATERIALS HANDLING**

**WEAR SOLUTIONS**

**FLOW & INDUSTRIAL**

**INSTRUMENTATION**

**POWER GENERATION**

**GEOTECHNICAL**

AUSTRALIA - NEW ZEALAND - INDONESIA - SOUTH AFRICA

[www.hmagrp.com](http://www.hmagrp.com)