

A Slurry valve for life

VALVECO IS A DIVISION OF HALLEY & MELLOWES GROUP OF COMPANIES



The **Technegate™** Knife Gate Valve is a true bi-directional slurry knife gate valve. Its massive rubber sleeves were designed to seal and withstand the harsh abrasive duty inherent in mining and milling facilities.

The **Technegate™** Knife Gate Valve includes the following standard features;

- Fluorocarbon coated 316L stainless steel gate to reduce wear, build-up of scale and strokes times
- Zinc-Nickel Plated Hardware
- Epoxy Paint
- Bi-Directional Operation rated for 100PSI
- No Packing to bind the gate
- CNC machined gate guide & body
- Low Durometer Seats for maximum erosion protection
- ANSI B16.5 Class 150, AS2129 table D/E flange drilling pattern
- All air cylinder actuated valves are supplied with an internal ring magnet for position indication
- Prompt Deliveries
- Heavy weight ductile iron

Optional Features include:

- Cylinder Mounted proximity switches (non-contacting)
- Splash Guard with 2 FNPT Ports
- Seats available in pure gum rubber / neoprene / chlorobutyl / E.P.D.M.
- Lock Outs
- Solenoid valves with manual override and power indication LED
- ETFE coatings for corrosive applications
- 17-4 PH gates for higher operating pressure (150PSI)



Tails Line Valves with Hydraulic Actuators



Cyclone Isolation Valve

VALVE SIZE		3"	4"	6"	8"	10"	12"	14"	16"	18"	20"	24"	30"
Face to Face ¹ (installed)	Inches	5.75	5.75	5.86	6.13	8.69	9.88	9.88	10.75	11.88	13.88	14.38	15.55
	mm	146	146	149	156	221	251	251	273	302	353	365	395
Max. Height ² From Centreline	Inches	27.44	31.44	38.75	44.75	51.50	58.81	64.50	72.94	81.69	88.50	105.38	123.82
	mm	696	799	983	1136	1309	1494	1638	1853	2069	2248	2677	3145
Max. Width	Inches	9.13	11	13	15.25	16.5	21	22.75	25	42.75	43.2	48.5	41.5
	mm	232	279	330	387	419	533	578	635	1060	1097	1232	1054
Max. Oper. Pressure	Psi	100	100	100	100	100	100	100	100	100	100	75	75
	kPa	689	689	689	689	689	689	689	689	689	689	520	520
Weight	Kg	30	36	61	77	98	277	298	472	564	695	923	977*

¹ Allow 1/4" to 1/2" for ease of installation ² Max widths & heights are based on air cylinder actuated valve

Actuator Options-Air Cylinder, Handwheel, Bevel Gear, Hydraulic and Electric

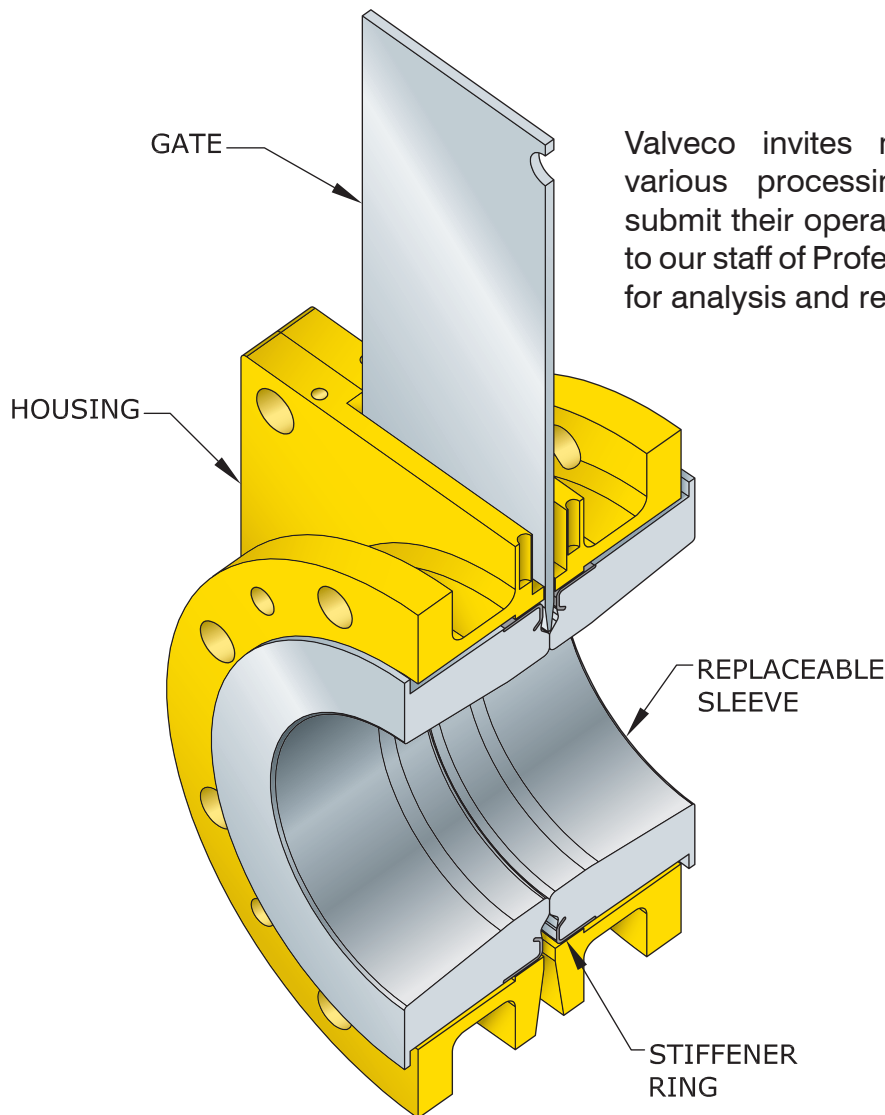

Valveco invites members of the various processing industries to submit their operating requirements to our staff of Professional Engineers for analysis and recommendations.

Note

The designs, materials, dimensions and specifications shown are subject to change without notice due to our continuing program of product development.

NSW

Wyong - Head Office

10 Hereford Street, Berkeley Vale NSW 2261
PO Box 5010 Chittaway NSW 2261
Tel: +61 (0)2 4389 6191
Fax: + 61 (0)2 4389 6199
Email: info@hmagroup.com.au

Sydney

13 Sirius Road, Lane Cove NSW 2066
Tel: +61 (0)2 9428 7300
Fax: +61 (0)2 9428 7399
Email: sydney@hmagroup.com.au

Singleton

21 Magpie St, McDougall's Hill, NSW 2330
Tel: +61 (0)2 6571 8200
Fax: +61 (0)2 6571 8299
Email: singleton@hmagroup.com.au

QLD

Brisbane

Building 107, unit 3B, 2-6 Leonardo Drive,
Hamilton Central, QLD 4007
PO Box 999, Hamilton Central, QLD 4007
Tel: +61 (0)7 3859 6800
Fax: +61 (0)7 3859 6869
Email: brisbane@hmagroup.com.au

Mackay

22-30 Southgate Drive,
Southgate Industrial Park, Paget QLD 4740
PO Box 6221, Mackay Mail Centre QLD 4741
Tel: +61 (0)7 4998 6900
Fax: +61 (0)7 4998 6999
Email: mackay@hmagroup.com.au

Gladstone

9 Neil St, Gladstone QLD 4680
PO Box 1731, Gladstone QLD 4680
Tel: +61 (0)7 4973 5500
Fax: +61 (0)7 4973 5599
Email: gladstone@hmagroup.com.au

WA

Perth

119 Dowd Street, Welshpool WA 6106
Tel: +61 (0)8 6254 9500
Fax: +61 (0)8 6254 9599
Email: perth@hmagroup.com.au

VIC

Melbourne

11/97 Bayfield Road East, Bayswater VIC 3153
Tel: +61 (0)3 8720 6700
Fax: +61 (0)3 8720 6799
Email: melbourne@hmagroup.com.au

Morwell

8 Jones Road, Morwell VIC 3840
Tel: + 61 (0)3 5136 8400
Fax: +61 (0)3 5136 8499
Email: morwell@hmagroup.com.au

NEW ZEALAND

Hamilton

Unit 9, 9 Karewa Place, Pukete, Hamilton NZ 3200
PO Box 10102, Te Rapa Hamilton NZ 3241
Tel: +64 (0)7 847 1880
Fax: +64 (0)7 847 1883
Email: hamilton@hmagroup.co.nz

Dunedin

Mobile: +64 (0) 275 116 694
Email: dunedin@hmagroup.co.nz

INDONESIA

Jakarta

Indonesian Representative Office of Halley & Mellowes Pty. Ltd. (HMA Group)
Menara Karya 28th Floor,
Jalan H.R. Rasuna Said Blok X-5, Kav 1-2
Jakarta 12950, Indonesia
Mobile: +62 (811) 9855 765
Tel: +62 21 5789 5525
Fax: +62 21 5789 5888
Email: jakarta@hmagroup.com.au

Halley & Mellowes Australasia Group of Companies

