

# WF-18 Belt Feeder



## WEIGH THE ADVANTAGES

The Tecweigh® WF18 is a stainless steel, wash down weigh belt feeder that has proven itself in many different industries including food, pharmaceutical and chemical. The feeder is designed to meet FDA and USDA construction standards. It features welded 303/304 stainless steel construction and can provide product flow rates ranging from 100 lbs./hr. to 250,000 lbs./hr.

The WF18's construction provides a weigh feeder that is rugged, yet can still handle the lowest flow rates accurately. The belt glides on a smooth, flat UHMW slider bed that reduces friction, vibration, and scale disturbance for greater scale accuracy.

A variety of belt options are available to suit your conveying requirements. Our innovative frame design minimizes material build up areas and maximizes accessibility. Standard shaft mounted reducers and C-Face motor drive arrangements are safe and easy to clean. With optional quick release take-ups and cantilevered frame design, the WF18's belt may be removed and replaced in seconds without the use of tools. This allows easy clean up and reduced maintenance time.

The WF18 weigh belt feeder with it's standard WP20 weight processor can be used to monitor the actual material flow rate, and record the total amount of product delivered. When used with optional Tecweigh processors, the WF18 can control the flow rate or batch amount for your specific application.

Weigh the advantages yourself. See why more and more companies are choosing Tecweigh as Their way.

Feed and meter bulk material with confidence; from pounds per minute to tons per hour, our dependable WF18 weigh belt feeders provide you with the exact status of the material in transit.

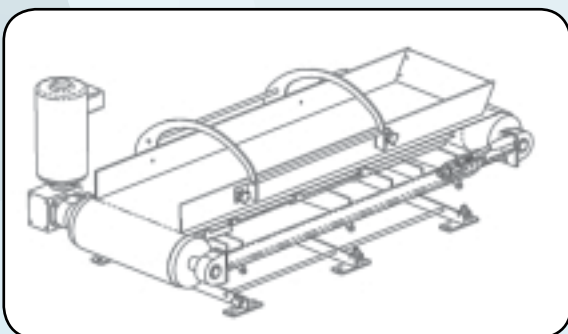

## WP20 ELECTRONIC WEIGHT PROCESSOR

The WP20 processor is recognised as an industry leader. Its easy to read; easy to understand face plate provides reassurance to the

operators that they will have a trouble free installation or calibration. Put your weighing in the hands of Tecweigh; Accurate, Dependable and Affordable.

## STANDARD FEATURES

- Rugged construction
- 303/304 stainless steel construction
- Shaft mounted worm gear reducer
- Lengths from 4' to 30'
- Food-grade belts from 9" to 48"
- Corrugated urethane side wall belt
- Glass bead blasted finish
- Adjustable tube-in-tube take-ups
- Easily replaceable UHMW slider strips
- 230/460 volt, 3 Ph, 60 hz TENV motor
- WP20 weight processor



MAT-DS-0042 AUG. 2019