

KEY FEATURES

- Limits system pressure by relieving excess flow
- Quick opening relief
- Easily adjustable pressure setting

PRODUCT OVERVIEW

The 106-RPS and 206-RPS pressure relief valves are based on the 106-PG and 206-PG main valves. The 81-RP pilot senses the upstream pressure through a connection to the valve inlet. The valve and pilot remain closed until the inlet pressure exceeds the pilot setting. The valve opens rapidly to relieve damaging overpressure and closes smoothly at an adjustable speed, when the pressure returns below the set-point. The upstream pressure is limited to the pilot set-point.

TYPICAL APPLICATION

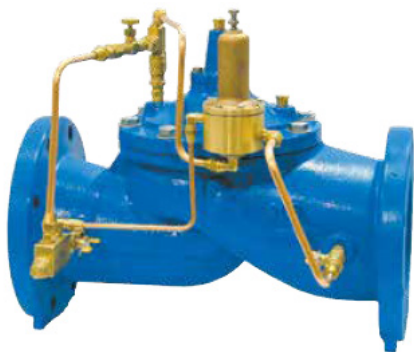
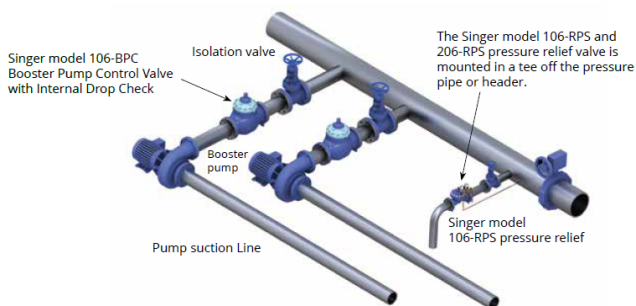

SCHEMATIC DRAWING

1. Main Valve - 106-PG or 206-PG
2. Isolation Valve - standard 4 in / 100 mm and larger
3. Strainer - standard 4 in / 100 mm and larger
4. Fixed Restriction- 1/8 in / 3.2 mm
5. Model 852-B Closing Speed Control
6. Model 81-RP pilot
- Specify for 5 to 50 psi / 0.35 to 3.5 bar, 10 to 80 psi / 0.70 to 5.5 bar, 20 to 200 psi / 1.38 to 13.8 bar, 100 to 300 psi / 6.9 to 20.7 bar.
7. Isolation Valve - standard 4 in / 100 mm and larger
8. Isolation Valve - standard all sizes

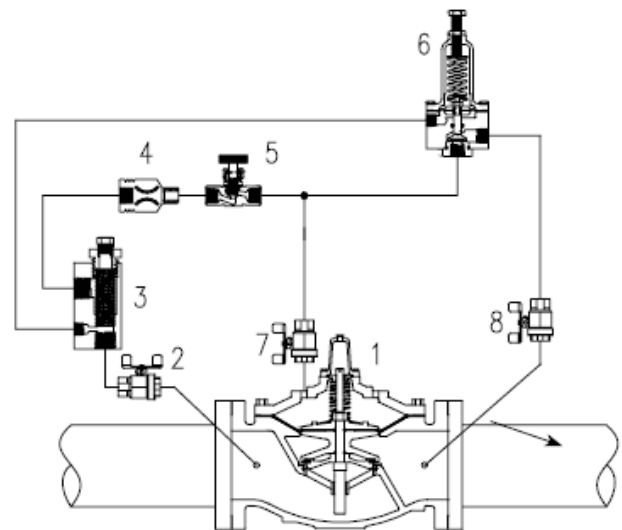

Schematic A-0423F

STANDARD MATERIALS

Standard materials for pilot system components are:

- ASTM B62 bronze or ASTM B16 brass
- AISI 303/316 stainless steel trim
- Buna-N / EPDM diaphragm and seals

SELECTION SUMMARY

1. Select the valve with sufficient capacity using the available pressure drop across the valve.
2. Usually operating in the momentary "M" service range.
3. For extended or continuous relief applications, use model 106-RPS-AC: Pressure Relief with AntiCavitation Cages.
4. Ensure that the maximum working pressure rating for the valve and for the flanges exceeds the maximum operating pressure.
5. Select a standard globe style body or the optional angle style body.

ORDERING INSTRUCTIONS

Refer to page 244 for the order form and ordering instructions. Additionally, include the following information for this product:

1. Single chamber (106) or (206)
2. Relief pressure range
3. Outlet pressure

FLOW CAPACITY - RELIEF

106-RPS	Flow Capacity 45 ft / s or 14 m / s (See 106-PG in Main Valve section for other valve data)								
Size (inches)	1/2 in	3/4 in	1 in	1-1/4 in	1-1/2 in	2 in	2-1/2 in	3 in	4 in
Size (mm)	15 mm	19 mm	25 mm	32 mm	40 mm	50 mm	65 mm	80 mm	100 mm
Momentary (USGPM)	28	43	110	170	250	470	670	1030	1800
Momentary (L/s)	2	3	7	11	16	30	42	65	114

106-RPS	Flow Capacity 45 ft / s or 14 m / s (See 106-PG in Main Valve section for other valve data)								
Size (inches)	6 in	8 in	10 in	12 in	14 in	16 in	20 in	24 in	36 in
Size (mm)	150 mm	200 mm	250 mm	300 mm	350 mm	400 mm	500 mm	600 mm	900 mm
Momentary (USGPM)	4000	7000	11000	16000	19000	25000	39000	56200	124700
Momentary (L/s)	252	442	694	1009	1199	1577	2461	3546	7868

206-RPS	Flow Capacity 45 ft / s or 14 m / s (See 206-PG in Main Valve section for other valve data)								
Size (inches)	3 in	4 in	6 in	8 in	10 in	12 in	16 in	18 in	20 in
Size (mm)	80 mm	100 mm	150 mm	200 mm	250 mm	300 mm	400 mm	450 mm	500 mm
Momentary (USGPM)	564	1236	2160	4800	8400	13200	19200	30000	30050
Momentary (L/s)	36	78	136	303	530	833	1211	1893	1896

206-RPS	Flow Capacity 45 ft / s or 14 m / s (See 206-PG in Main Valve section for other valve data)							
Size (inches)	24 x 16 in	24 x 20 in	28 in	30 in	32 in	36 in	40 in	
Size (mm)	600 x 400 mm	600 x 500 mm	700 mm	750 mm	800 mm	900 mm	1000 mm	
Momentary (USGPM)	30100	39000	67440	67490	67540	67640	62000	
Momentary (L/s)	1899	2461	4255	4258	4261	4268	3912	